

Prepared For: _____

Presented By:
 Southwest International Trucks, Inc.
 Hayes Atwood
 3722 Irving Blvd.
 Dallas TX 75247 -
 (214)689-1400

Thank you for the opportunity to provide you with the following quotation on a new International truck. I am sure the following detailed specification will meet your operational requirements, and I look forward to serving your business needs.

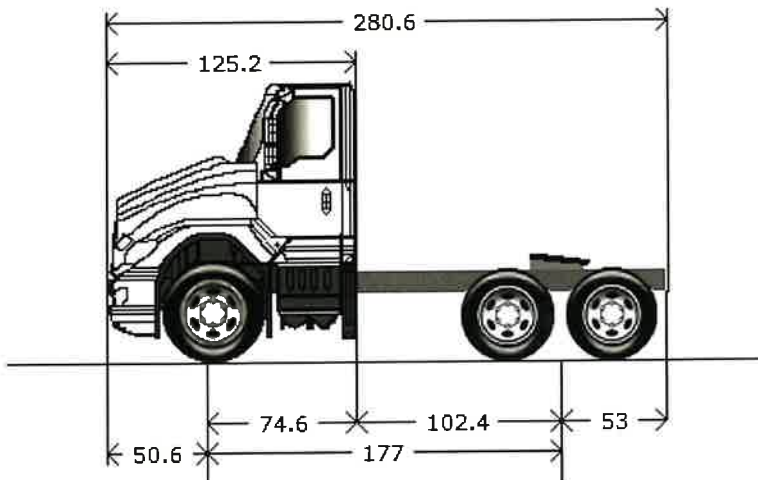

Model Profile
2021 LT625 6x4 (LT62F)

- APPLICATION:** General Freight Regional Haul 6x2/6x4 (DayCab)
- MISSION:** Requested GCWR: 80000. Calc. GCWR: 95000. Calc. GVWR: 52350
 Calc. Start / Grade Ability: 17.40% / 1.19% @ 65 MPH
 Calc. Geared Speed: 92.9 MPH
- DIMENSION:** Wheelbase: 177.00, CA: 102.40, Axle to Frame: 53.00
- ENGINE, DIESEL:** {Cummins X15 450 EX} Efficiency Series, EPA 2017, 450HP @ 1700 RPM, 1750 lb-ft Torque @ 950 RPM, 1700 RPM Governed Speed, 461 Peak HP (Max)
- TRANSMISSION, MANUAL:** {Eaton Endurant EEO-17F112C} 12-Speed Fully Automated Manual, Aluminum Clutch Housing, Overdrive, Mechatronic Shift Controls, Pneumatic Clutch Actuation, Internal Lube Oil Pump, Hill Start Aid
- CLUTCH:** {Eaton Fuller 430MM} Maintenance Free; Single Plate Diaphragm Spring, Organic, (430 mm) 17" Diameter, 5-Spring Coaxial Design with Pre-Damper, with 2.00" 18 Tooth Spline, Non-Adjustable, (2508 Nm) 1850 lb-ft Capacity
- AXLE, FRONT NON-DRIVING:** {Hendrickson Steertek NXT} Wide Track, Fabricated Type, 12,350-lb Capacity
- AXLE, REAR, TANDEM:** {Meritor MT-40-14X-3CFR} Single Reduction, Amboid Gearing in Rear-Rear Axle, 40,000-lb Capacity, .374"(9.5mm) Wall Housing Thickness, R Wheel Ends Gear Ratio: 2.79
- CAB:** Conventional, Day Cab
- TIRE, FRONT:** (2) 275/80R22.5 Load Range G X LINE ENERGY Z (MICHELIN), 517 rev/mile, 75 MPH, All-Position
- TIRE, REAR:** (8) 275/80R22.5 Load Range G X LINE ENERGY D (MICHELIN), 514 rev/mile, 75 MPH, Drive
- SUSPENSION, REAR, AIR, TANDEM:** {International} Ride Optimized Suspension (IROS), 40,000-lb Capacity, 52" Axle Spacing, 9.25" Ride Height, with Shock Absorbers
- PAINT:** Cab schematic 100HX
 Location 1: 9219, Winter White (Std)
 Chassis schematic N/A

<u>Code</u>	<u>Description</u>	<u>F/R Wt</u> (lbs)	<u>Tot Wt</u> (lbs)
LT62F00	Base Chassis, Model LT625 6x4 with 177.00 Wheelbase, 102.40 CA, and 53.00 Axle to Frame.	8019/6646	14665
1570	TOW HOOK, FRONT (2) Frame Mounted	22/0	22
1616	FRAME RAILS WITH TAPERED REAR	0/0	0
1CBV	FRAME RAILS Heat Treated Alloy Steel (120,000 PSI Yield); 10.125" x 3.580" x 0.312" (257.2mm x 90.9mm x 8.0mm); 367.4" (9333mm) Maximum OAL	37/41	78
1LEJ	LICENSE PLATE HOLDER Front	2/0	2
1LRL	BUMPER, FRONT 3-Piece, Aerodynamic, Plastic, Molded Dark Gray	0/0	0
1MED	BUMPER EFFECTS Includes Air Dam and Bumper Seal, Air Dam Extends 3.25" below the Bumper	4/0	4
1WKJ	WHEELBASE RANGE 152" (385cm) Through and Including 185" (470cm)	0/0	0
1WLS	DECK PLATE Aluminum, (2) Sections, Flush Mounted	2/14	16
2AUD	AXLE, FRONT NON-DRIVING {Hendrickson Steertek NXT} Wide Track, Fabricated Type, 12,350-lb Capacity	12/0	12
3AJM	SUSPENSION, FRONT, SPRING Monoleaf, Shackle Type, 12,350-lb Capacity, with Shock Absorbers	-45/0	-45
4092	BRAKE SYSTEM, AIR Dual System for Tractor Applications	0/0	0
	<u>Includes</u>		
	: BRAKE LINES Color and Size Coded Nylon		
	: BRAKE PRESSURE INDICATOR Low Air Pressure Warning Light and Audible Alarm		
	: DRAIN VALVE Manually Operated (On Wet Tank Only)		
	: GAUGE, AIR PRESSURE (2) Air 1 and Air 2 Gauges; Located in Instrument Cluster		
	: GLAD HANDS (2) One for Service and One for Emergency; Trailer Hoses from Cab		
	: HAND CONTROL VALVE, AIR with Self Return Handle, for Trailer Brakes, Mounted in Instrument Panel		
	: HOSE TENDER Back of Cab Mounted		
	: PARKING BRAKE CONTROL Yellow and Red Knobs, Located on Instrument Panel		
	: PARKING BRAKE VALVE Combination Valve for Tractor and Trailer		
	: QUICK RELEASE VALVE On Rear Axle for Spring Brake Release: 1 for Forward Rear Axle		
	: TRACTOR PROTECTION VALVE		
	: TRAILER HOSES AND CABLES 15' Coiled Lighting Cable with 7-Way Connector and with 15' Coiled Nylon Brake Hose		
	<u>Notes</u>		
	: Front and Rear Dust Shields not Included		
	: Rear Axle is Limited to 40,000-lb GAWR with Code 04092 BRAKE SYSTEM, AIR and Standard Rear Air Cam Brakes Regardless of Axle/Suspension Ordered		
4803	TRAILER HOSES AND CABLES Straight, Rubber Hose, 14' Working Length, Aluminum Glad Hands with Rubber Seals, Lighting Cable with Nylon Plug	8/5	13
4809	HOSE TENDER Slide Bar with Double Spring Bracket, Bar Extended 4" from Cab	9/6	15
4AZY	AIR BRAKE ABS {Bendix AntiLock Brake System} 6-Channel (6 Sensor/6 Modulator) Electronic Stability Program, with Automatic Traction Control	5/2	7

<u>Code</u>	<u>Description</u>	<u>F/R Wt</u> (lbs)	<u>Tot Wt</u> (lbs)
4EDJ	AIR DRYER {Bendix AD-IS} with Heater, Includes Pressure Protection Circuits, Safety Valve, Integral Purge Tank, Integrated PuraGuard Coalescing Filtration	0/0	0
4EXU	BRAKE CHAMBERS, REAR AXLE {Bendix EverSure} 30/30 SqIn Spring Brake <u>Includes</u> : BRAKE CHAMBERS, POSITION (2) Rear Parking; WITH TRUCK BRAKES: All 4x2, 4x4; WITH TRACTOR BRAKES: All 4x2, 4x4; 6x4 & 6x6 with Rear Tandem Axles Less Than 46,000-lb. or GVWR Less Than 54,000-lb. : BRAKE CHAMBERS, POSITION (4) Rear Parking; WITH TRUCK BRAKES: All 6x4, 6x6; WITH TRACTOR BRAKES: 6x4 & 6x6 with Rear Tandem Axles 46,000-lb. or Greater or GVWR of 54,000-lb. or Greater	0/14	14
4EXV	BRAKE CHAMBERS, FRONT AXLE {Bendix} 24 SqIn	4/0	4
4GBH	TRAILER CONNECTION BRACKETS Mounted Lower Left Side of Day Cab	9/6	15
4LAA	SLACK ADJUSTERS, FRONT {Haldex} Automatic	14/0	14
4LGA	SLACK ADJUSTERS, REAR {Haldex} Automatic	0/32	32
4SPA	AIR COMPRESSOR {Cummins} 18.7 CFM	-2/0	-2
4SUT	TRAILER CONNECTIONS Trailer Brake Air Lines Located next to 7-Way ABS Connector	0/0	0
4UKP	AIR TANK, AUXILIARY for Transmission Air Supply, Frame Mounted Under Right Rail, Under Cab	19/7	26
4VHW	AIR TANK LOCATION (2) Mounted Under Battery Box, Outside Left Rail, Under Cab; Perpendicular to Rail	0/0	0
4WDU	HAND CONTROL VALVE, AIR for Trailer Brakes, Omit Item	0/0	0
4WXR	DRAIN VALVE (2) {Berg} with Pull Chains, for Air Tanks	2/0	2
4XDH	BRAKES, REAR {Bendix Spicer ES-165-7L} Air S-Cam Type, Light Weight Fabricated Spider, Fabricated Shoe, Single Anchor Pin, Size 16.5" X 7", 20,000-lb Capacity per Axle	0/81	81
4XDK	BRAKES, FRONT {Bendix Spicer ES-165-5X} Air S-Cam Type, Heavy Duty Fabricated Spider, Fabricated Shoe, Single Anchor Pin, Size 16.5" X 5", 14,600-lb Capacity	-22/0	-22
4XEE	PARK BRAKE CHAMBERS, ADDITIONAL (2) Spring Brake Type	0/30	30
5710	STEERING COLUMN Tilting and Telescoping	0/0	0
5CAW	STEERING WHEEL 4-Spoke; 18" Dia., Black	0/0	0
5PSM	STEERING GEAR {Sheppard HD94} Power	0/0	0
5WAJ	POWER STEERING OIL COOLER Remote Mounted	4/0	4
6DGX	DRIVELINE SYSTEM {Dana Spicer} Service Free SPL250 Main Driveline with SPL170 Interaxle Shaft, for 6x4	0/0	0
7BKP	EXHAUST SYSTEM Single, Horizontal Aftertreatment Device, Frame Mounted Right Side Under Cab, for Single Short Horizontal Tail Pipe, Frame Mounted Right Side Back of Cab	0/0	0
7SAP	ENGINE COMPRESSION BRAKE {Cummins} Interbrake For Cummins Signature/ ISX/X15 Engines; Furnished with Engine	0/0	0
7WDR	TAIL PIPE (1) Horizontal, Short, with Heat Diffuser	0/0	0

<u>Code</u>	<u>Description</u>	<u>F/R Wt</u>	<u>Tot Wt</u>
		(lbs)	(lbs)
8000	ELECTRICAL SYSTEM 12-Volt, Standard Equipment <u>Includes</u> : DATA LINK CONNECTOR For Vehicle Programming and Diagnostics In Cab : HAZARD SWITCH Push On/Push Off, Located on Instrument Panel to Right of Steering Wheel : HEADLIGHT DIMMER SWITCH Integral with Turn Signal Lever : HORN, ELECTRIC Single : PARKING LIGHT Integral with Front Turn Signal and Rear Tail Light : POWER SOURCE Cigar Type Receptacle with Cap, USB Port, Located in Instrument Panel : STARTER SWITCH Electric, Key Operated : TURN SIGNAL SWITCH Manual Cancelling with Lane Change Feature : TURN SIGNALS, FRONT Includes Reflectors and Auxiliary Side Turn Signals, Solid State Flashers; Flush Mounted : WINDSHIELD WIPER SWITCH 2-Speed with Wash and Intermittent Feature (5 Pre-Set Delays), Integral with Turn Signal Lever : WINDSHIELD WIPERS Single Motor, Electric, Cowl Mounted : WIRING, CHASSIS Color Coded and Continuously Numbered	0/0	0
8GHU	ALTERNATOR {Delco Remy 28SI} Brush Type, 12 Volt, 200 Amp Capacity, Pad Mount, with Remote Sense	-2/0	-2
8MWC	BATTERY SYSTEM {Deka/EAST PENN 7T31} Maintenance-Free, (4) 12-Volt 2920CCA Total, Top Threaded Stud	56/30	86
8RBZ	SPEAKER, AUXILIARY, CB RADIO with Jack for CB; Mounted Left Side Above Driver's Door	2/0	2
8RMV	SPEAKERS (2) 6.5" Dual Cone Mounted in Doors	0/0	0
8RND	CB RADIO Accommodation Package; Header Mounted; Feeds From Accessory Side of Ignition Switch; Includes Power Source and One (1) Antenna, Antenna Base with Wiring on Left Side, Back of Cab	0/0	0
8RPS	RADIO AM/FM/WB/Clock/Bluetooth/USB Input/Auxiliary Input	0/0	0
8TPP	STOP, TURN, TAIL & B/U LIGHTS Multi-Function Lamp, with LED Lights for Stop, Turn, Tail and Backup Lights, Includes LED License Plate Light	0/0	0
8TPU	COLLISION MITIGATION SYSTEM {Bendix Wingman Fusion} Adaptive Cruise Control w/Collision Mitigation & Stationary Vehicle Braking, Stationary Object Alert, Lane Departure Warning, Overspeed Alert & Action; Includes Front Radar & Camera, Driver Display, Lane Departure Warning Switch & Speakers; Safety Direct Capability, less Safety Direct Cable	0/0	0
8TSB	COLLISION WARNING SYSTEM {Bendix BlindSpotter} Side Object Detection System; Includes Right Side Antenna & Side Display	2/0	2
8VTV	STOP-LIGHT WIRING MODIFIED Stop-Lights Turned on When Engine Compression Brake, Exhaust Brake or Retarder is Activated	0/0	0
8WEZ	TURN SIGNAL SWITCH Self-Canceling	0/0	0
8WPZ	TEST EXTERIOR LIGHTS Pre-Trip Inspection will Cycle all Exterior Lamps Except Back-up Lights	0/0	0
8WRB	HEADLIGHTS ON W/WIPERS Headlights Will Automatically Turn on if Windshield Wipers are turned on	0/0	0
8WTL	STARTING MOTOR {Delco Remy 39MT} 12 Volt, Gear Reduced, with Thermal Over-Crank Protection	0/0	0

<u>Code</u>	<u>Description</u>	<u>F/R Wt</u> (lbs)	<u>Tot Wt</u> (lbs)
8WXB	HEADLIGHT WARNING BUZZER Sounds When Head Light Switch is on and Ignition Switch is in "Off" Position	0/0	0
8WXD	ALARM, PARKING BRAKE Electric Horn Sounds in Repetitive Manner When Vehicle Park Brake is "NOT" Set, with Ignition "OFF" and any Door Opened	0/0	0
8XAH	CIRCUIT BREAKERS Manual-Reset (Main Panel) SAE Type III with Trip Indicators, Replaces All Fuses	0/0	0
8XDP	HEADLIGHTS Halogen, with Park Lights and Daytime Running Lights	-15/2	-13
8XHK	BATTERY BOX Aluminum, 30" Wide, 2-4 Battery Capacity, Mounted Left Side Under Cab	-32/-13	-45
8XHN	HORN, AIR Single Trumpet, Black, with Lanyard Pull Cord	0/0	0
8XHR	POWER SOURCE, ADDITIONAL Auxiliary Power Outlet (APO) & USB Port, Located in the Instrument Panel	0/0	0
8XHX	SWITCH, MARKER INTERRUPT for Marker Lights and Headlights, Located in Steering Wheel	0/0	0
8XJC	BATTERY WIRING MODIFICATION Battery Discharge Protection System; Control thru Body Controller	0/0	0
8XMB	CONNECTOR, DASH, CENTER PANEL Cab Wiring for TMC RP1226 Vehicle Accessory Connector; Includes 14-pin Connector with Switched Power, Battery Power, Ignition Power, Ground & Body 250K Datalink, Connector Located Behind Instrument Panel Center Console	3/0	3
9AAB	LOGOS EXTERIOR Model Badges	0/0	0
9AAE	LOGOS EXTERIOR, ENGINE Badges	0/0	0
9AAG	HOOD, FRONT FILLER SEAL Mounted Between Bumper and Hood	0/0	0
9HAD	GRILLE Chrome	0/0	0
9WAY	FRONT END Tilting, Fiberglass, with Three Piece Construction	0/0	0
	<u>Includes</u> : BUG SCREEN Front End; Mounted Behind Grille : HOOD TILT ASSIST Includes Torsion Bar Spring System		
10060	PAINT SCHEMATIC, PT-1 Single Color, Design 100	0/0	0
	<u>Includes</u> : PAINT SCHEMATIC ID LETTERS "HX"		
10469	LABEL, SMARTWAY US EPA Qualified, Meets SmartWay Specifications	0/0	0
10761	PAINT TYPE Base Coat/Clear Coat, 1-2 Tone	0/0	0
10ADT	COMMUNICATIONS MODULE Telematics Device with Over the Air Programming; Includes Two Year Data Plan	1/0	1
10HZN	FIFTH WHEEL, AIR SLIDE {Fontaine SL6NWB675012} 12" Slide, 6.75" Above Top of Frame, Left Hand Release	0/0	0
10VAA	KEYS - ALL ALIKE, ADDITIONAL 3 Keys	0/0	0
10WKL	KEYS - ALL ALIKE, ID I-1604 Compatible with Z-150	0/0	0
10WRM	MUD FLAP HOLDER {Betts B-35} .640" Square, 45-Degree End, Aluminum Plate with Red and White Reflective Tape, Less Flaps	0/0	0

<u>Code</u>	<u>Description</u>	<u>F/R Wt</u> (lbs)	<u>Tot Wt</u> (lbs)
10WSJ	MUD FLAPS, REAR Black Poly, Anti-Sail, with Upper Corners Cut Off at 45-Degrees, Less Holders, Mounting Holes in Flaps for Betts B-35 Brackets	0/8	8
10WTR	QUARTER FENDERS for Rear Wheels, Black Plastic; Frame Mounted	0/18	18
11MHM	CLUTCH {Eaton Fuller 430MM} Maintenance Free; Single Plate Diaphragm Spring, Organic, (430 mm) 17" Diameter, 5-Spring Coaxial Design with Pre-Damper, with 2.00" 18 Tooth Spline, Non-Adjustable, (2508 Nm) 1850 lb-ft Capacity	0/0	0
12703	ANTI-FREEZE Red, Extended Life Coolant; To -40 Degrees F/ -40 Degrees C, Freeze Protection	0/0	0
12864	BLOCK HEATER, ENGINE {Phillips} 120V/1500W <u>Includes</u> : BLOCK HEATER SOCKET Receptacle Type; Mounted below Drivers Door	2/0	2
12EUH	ENGINE, DIESEL {Cummins X15 450 EX} Efficiency Series, EPA 2017, 450HP @ 1700 RPM, 1750 lb-ft Torque @ 950 RPM, 1700 RPM Governed Speed, 461 Peak HP (Max)	616/61	677
12TKY	FAN DRIVE {Borg-Warner K32} On/Off Type, Pneumatic Actuated	-15/1	-14
12VBY	AIR CLEANER Single Element, Engine Mounted <u>Includes</u> : GAUGE, AIR CLEANER RESTRICTION Air Cleaner Mounted	0/0	0
12VHE	FEDERAL EMISSIONS {Cummins X15} EPA, OBD and GHG Certified for Calendar Year 2020	0/0	0
12WGA	HOSE CLAMPS, RADIATOR HOSES , Mechanical Type; with Constant-Tension Functionality	0/0	0
12WYZ	RADIATOR DRAIN & FILL FITTING SPECIAL; To Vacuum Out or Fill the Cooling System from the Bottom of Radiator, for Use with Quick-Connect Radiator Drain Tool or Shop Coolant Evacuation-Fill System	0/0	0
12WZJ	EMISSION COMPLIANCE Low NOx Idle Engine, Complies with California Clean Air Regulations; Includes "Certified Clean Idle" Decal located on Driver Door	0/0	0
12XBC	RADIATOR Aluminum, Welded, Down Flow, Front to Back System, 1325 SqIn, with 806 SqIn Charge Air Cooler	0/0	0
12XBE	CRUISE CONTROL Predictive, Includes GPS Enhanced Cruise Control; Includes Module, Antenna and Wiring	0/0	0
13GZB	TRANSMISSION, MANUAL {Eaton Endurant EEO-17F112C} 12-Speed Fully Automated Manual, Aluminum Clutch Housing, Overdrive, Mechatronic Shift Controls, Pneumatic Clutch Actuation, Internal Lube Oil Pump, Hill Start Aid <u>Notes</u> : A temperature gauge is not available with the Endurant transmission. The Endurant monitors temperature and will display a warning in the gauge cluster when temperature is over the limit allowed.	0/0	0
13WET	TRANSMISSION SHIFT CONTROL Column Mounted Stalk Shifter, Not for Use with Allison 1000 & 2000 Series Transmission	1/0	1
13WLW	TRANSMISSION OIL {EmGard 40W} Synthetic; 1 thru 21.99 Pints	0/0	0
13XAN	PTO LOCATION Customer Does Not Intend to Install PTO	0/0	0

<u>Code</u>	<u>Description</u>	<u>F/R Wt</u> (lbs)	<u>Tot Wt</u> (lbs)
13XAX	SHIFT CONTROL PARAMETERS {Eaton Endurant} Automated Manual Transmission, Economy Calibration	0/0	0
14899	SUSPENSION AIR CONTROL VALVE Pressure Release Control In Cab	6/2	8
14GVD	AXLE, REAR, TANDEM {Meritor MT-40-14X-3CFR} Single Reduction, Amboid Gearing in Rear-Rear Axle, 40,000-lb Capacity, .374"(9.5mm) Wall Housing Thickness, R Wheel Ends . Gear Ratio: 2.79	0/0	0
	<u>Includes</u> : POWER DIVIDER LOCK Electric over Air Operated, Cab Control with Indicator Light		
	<u>Notes</u> : When Specifying Axle Ratio, Check Performance Guidelines and TCAPE for Startability and Performance		
14UPZ	SUSPENSION, REAR, AIR, TANDEM {International} Ride Optimized Suspension (IROS), 40,000-lb Capacity, 52" Axle Spacing, 9.25" Ride Height, with Shock Absorbers	0/0	0
14WNS	AXLE, REAR, LUBE {EmGard XFE-75W-85} Synthetic Oil; 50 thru 64.99 Pints	0/0	0
15EAC	FUEL TANK (2) Top Draw, Non-Polished Aluminum, 26" Dia, 80 US Gal (303L); Total Capacity 160 US Gal (606L), with Dual Supply and Return Lines, Less Equalizer Line, Mounted Left and Right Side, Back of Cab/Under Sleeper	37/61	98
15LKX	FUEL/WATER SEPARATOR {Davco Fuel Pro 382} 12 VDC Electric Heater, Includes Pre-Heater, Includes Water-in-Fuel Sensor	3/0	3
	<u>Includes</u> : LOCATION FUEL/WATER SEPARATOR Mounted Left Rail in Wheel Well		
15MAD	FUEL HEATER {Cummins} Omit Plumbing for TRV on Cummins Engines	-2/0	-2
15WDN	DEF TANK 15.9 US Gal (60L) Capacity, Frame Mounted Outside Left Rail, Back of Cab/Under Sleeper	3/1	4
16030	CAB Conventional, Day Cab	0/0	0
	<u>Includes</u> : CLEARANCE/MARKER LIGHTS (5) Flush Mounted : COAT HOOK, CAB Located on Rear Wall, Centered Above Rear Window : CONSOLE, CENTER Includes Two Cup Holders and One Additional Storage Area : COURTESY LIGHT (2) Driver and Passenger Door Mounted : DOME LIGHT, CAB Rectangular, Door and Instrument Panel Mounted Switch Activated, Timed Theater Dimming, Center Mounted, Integral to Console : FLOOR COVERING Rubber, Black : GLASS, ALL WINDOWS Tinted : GRAB HANDLE, CAB INTERIOR (1) "A" Pillar Mounted, Passenger Side : GRAB HANDLE, CAB INTERIOR (4) "B" Pillar and Door Mounted, Two Each Side : INTERIOR SHEET METAL Upper Door (Above Window Ledge) Painted Exterior Color : READING LIGHT, CAB Located in Overhead Console : STORAGE POCKET, DOOR (2) Full Length, Driver and Passenger Door		
16ATC	AUTOMATIC CLIMATE CONTROL Automatically Maintains Cabin Comfort Based on Selected Temperature	0/0	0
16BAM	AIR CONDITIONER with Integral Heater and Defroster	0/0	0
	<u>Includes</u> : HOSE CLAMPS, HEATER HOSE Mubea Constant Tension Clamps		

<u>Code</u>	<u>Description</u>	<u>F/R Wt</u> (lbs)	<u>Tot Wt</u> (lbs)
16GDG	GAUGE CLUSTER Premium Level; English with English Speedometer and Tachometer, for Air Brake Chassis, Includes Engine Coolant Temperature, Primary and Secondary Air Pressure, Fuel and DEF Gauges, Oil Pressure Gauge, Includes 5 Inch LCD Color Display <u>Includes</u> : GAUGE CLUSTER DISPLAY, Odometer, Voltmeter, Diagnostic Messages, Gear Indicator, Trip Odometer, Total Engine Hours, Trip Hours, MPG, Distance to Empty/ Refill for Fuel/DEF, DPF Level	0/0	0
16HGN	GAUGE, AIR APPLICATION	1/0	1
16HKE	GAUGE, LOAD INDICATING REAR Text Message in Cluster Display, for use with Rear Air Suspension	0/0	0
16HKT	IP CLUSTER DISPLAY On Board Diagnostics Display of Fault Codes in Gauge Cluster	0/0	0
16KAN	SEAT, DRIVER {National 2000 Model 195} Air Suspension, High Back, with Mordura Cloth, 2 Arm Rests, Isolator, 7" Adjuster, 1 Chamber Lumbar, 2 Position Front Cushion Adjust, 3-14 Degree Back Recline	2/0	2
16REM	SEAT, PASSENGER {National 2000} Non Suspension, High Back, Mordura Cloth, 2 Arm Rests 11 Degree Back Angle	6/2	8
16SNT	MIRRORS (2) Aero Pedestal, Power Adjust, Heated, Turn Signals, Black Heads and Arms, 6.5" x 14" Flat Glass, Includes 6.5" x 6" Convex Mirrors, for 102" Load Width <u>Notes</u> : Mirror Dimensions are Rounded to the Nearest 0.5"	0/0	0
16SSB	MIRROR, CONVEX, HOOD MOUNTED (2) Right and Left Sides, Breakaway, Black	10/-1	9
16UKN	LOAD LOCK HOLDERS Includes Four Compartment J-Locks, with Brackets and J-Lock Assemblies, Mounted on Back of Cab Right Side	3/0	3
16VKB	CAB INTERIOR TRIM Classic, for Day Cab <u>Includes</u> : DOOR TRIM, INTERIOR Black Handle : INSTRUMENT PANEL TRIM Black, Black Gauges with Black Bezels : SUN VISOR (2) Padded Vinyl; 2 Moveable (Front-to-Side) Primary Visors, Driver Side with Toll Ticket Strap	0/0	0
16VLV	MONITOR, TIRE PRESSURE Omit	0/0	0
16WJU	WINDOW, POWER (2) and Power Door Locks, Left and Right Doors, Includes Express Down Feature	0/0	0
16XJP	INSTRUMENT PANEL Wing Panel	0/0	0
16XRZ	CHASSIS SKIRTS, CAB LENGTH for Day Cab, Molded Dark Gray Color, for use with DEF Tank	42/78	120
16XZJ	AERODYNAMIC PACKAGE Includes Roof Air Deflector and 28" Wide Cab Side Extenders; for Day Cab, Paint and Install at the Plant	187/120	307
16ZHL	ACCESS, CAB AND FRAME Aluminum, Driver & Passenger Sides, Two Steps per Door; Left Side Frame Access Step, Includes One Flush Mounted Deck Plate and Black Grab Handle, for use with Day Cab or Sleeper Cab	48/26	74

<u>Code</u>	<u>Description</u>	<u>F/R Wt</u> (lbs)	<u>Tot Wt</u> (lbs)
27DVR	WHEELS, FRONT {Accuride 42644} DISC; 22.5x8.25 Rims, Standard Polish Aluminum, 10-Stud, 285.75mm BC, Hub-Piloted, Flanged Nut, with Aluminum Hubs	-78/0	-78
28DVR	WHEELS, REAR {Accuride 42644} DUAL DISC; 22.5x8.25 Rims, Standard Polish Aluminum, 10-Stud, 285.75mm BC, Hub-Piloted, Flanged Nut, with Aluminum Hubs	0/-257	-257
29BAG	WHEEL, REAR, IDENTITY Replace Inner Aluminum Wheels on Rear Duals with the Equivalent Steel Wheels - For Use with Hub Piloted Wheels Only	0/117	117
29WLK	WHEEL BEARING, FRONT, LUBE {EmGard FE-75W-90} Synthetic Oil	0/0	0
7602533279	(8) TIRE, REAR 275/80R22.5 Load Range G X LINE ENERGY D (MICHELIN), 514 rev/mile, 75 MPH, Drive	0/64	64
7602533286	(2) TIRE, FRONT 275/80R22.5 Load Range G X LINE ENERGY Z (MICHELIN), 517 rev/mile, 75 MPH, All-Position	-14/0	-14
810000	FIFTH WHEEL LOCATION On Rear Axle Centerline	0/0	0
Services Section:			
40125	WARRANTY Standard for LT/RH Series, Effective with Vehicles Built January 2, 2016 or Later, CTS-2010A	0/0	0
40TAU	SRV CONTRACT, EXT CMS ENG/AFTR {Cummins} To 60-Month/500,000 Miles (800,000 km), Extended Cummins X15 Efficiency or Productivity Series Engine Coverage, Protection Plan 1 and Aftertreatment	0/0	0
Total Component Weight:		8976/7204	16180

The weight calculations included in this proposal are an estimate of future vehicle weight. The actual weight as manufactured may be different from the estimated weight. Navistar, Inc. shall not be liable for any consequences resulting from any differences between the estimated weight of a vehicle and the actual weight.